

***Valtek Torex TX Control and Shut-off Valves***

Butterfly Valves

VLEETB4143-02 11.04



### Primary characteristics

Valtek Torex TX, High-Performance butterfly valve is available with either metal-to-metal or PTFE seat. Due to its unique design and triple offset, it closes extremely tight. It can be used both as a control valve and as a shut-off valve. This valve can be supplied in either wafer or lugged versions. The valve is available as standard in stainless steel and carbon steel. Contact Flowserve for more information.

The valve has:

- been designed according to the requirements in API 609.
- triple offset design enables the valve closure to be extremely tight
- small offset results in low operating torque in all control positions, so that low-torque actuators can be used.
- a special disc profile (segment of a toroid) - a principle which eliminates abrasive sliding action when the disc is opening and closing - ensures a longer service life.
- a high mean value of seating angle, so that the disc closes without tending to stick in the closed position, virtually eliminates any disk popping when opening the valve.
- PTFE lined bearings. For temperature above 250°C hard chromium stem, direct mounted in the body
- a one-piece valve body of stainless steel.
- a metallic or PTFE seat ring.
- the Flowserve NAF standard for mounting the actuator, which simplifies installation and results in a compact valve/actuator unit.

### CE-marked

According to Pressure Equipment Directive (PED 97/23/EG) module H, category III.

For module H1, category IV contact NAF

### Applications

Valtek Torex TX can be used both as a control valve and as a shut-off valve, in a wide variety of applications and in different operating modes.

The valve represents a concrete result of our product philosophy which is focused on functionality, high quality and low life cycle costs, and is based on concentrating our range to a limited number of valve types, but all of them suitable for a wide variety of applications.

The excellent characteristics of Torex TX are particularly beneficial in arduous control applications, in which difficult media and demanding pressure conditions make severe demands on the design, materials and performance.

Valtek Torex TX is recommended for applications in the following branches:

- Chemical and Petro Chemical
- Oil and gas

### Technical specification for standard design

Material:	Stainless steel CF8M, carbon steel WCB	
Size range:	DN 80-700, 3-28"	
Pressure ratings:	PN 10 - 25 ANSI Class 150	
Max. differential pressure:		
Valve closed	DN 80-700	25 bar
At 70° open valve	DN 80	8 bar
	DN 100	13 bar
(Limitation depending	DN 125	11 bar
of high velocity with	DN 150	6,5 bar
big dynamic torque	DN 200	4,5 bar
at this differential	DN 250	3 bar
pressure when valve	DN 300	2,7 bar
is open 70°)	DN 350	1,8 bar
	DN 400	2 bar
	DN 500	1,9 bar
	DN 600, 700	1,8 bar
	See also page 3	
Face-to-face lengths:	Wafer type PN 10-25 and ANSI Class 150: API standard 609 Class 150, size 28" EN 558, table 5, serie 20 Lug type ANSI Class 150: API standard 609 Class 150, size 28" EN 558, table 5, serie 20	
Valve design:	ANSI B 16.34 and EN 12516	
Installation method:	Wafer type and Lug type body	
Temperature range:	CF8M/1.4408	-30 - 350°C
	WCB/1.0619	-29 - 250°C
	(see product code)	
Test pressure:	1.5 x PN with valve open 1.1 x Max. differential pressure with valve closed.	
Sealing class:	PTFE seats: API 598 Metal seats: FCI 70-2, Class V, Test procedure type B. IEC 60534-4, Class V	
Painting of carbon steel valves:	One-component primer and finishing coat.	

**Flow capacities and characteristics (Table 1)  $K_v = C_v/1,16$**

DN	$C_v$ at an opening angle of								
	10°	20°	30°	40°	50°	60°	70°	80°	90°
80	17	37	60	87	116	151	186	232	244
100	24	53	99	133	180	238	302	389	412
125	38	87	142	202	273	379	545	705	783
150	44	110	186	290	418	586	795	1027	1102
200	70	174	302	499	754	1108	1543	1995	2169
250	107	284	499	818	1247	1821	2529	3277	3561
300	162	371	696	1172	1815	2616	3735	4907	5336
350	220	522	969	1566	2459	3579	5220	6856	7453
400	302	696	1288	2082	3173	4663	6844	9025	9918
500	487	1137	2111	3410	5197	7633	11206	14778	16240
600	731	1752	3213	5150	7702	11368	16681	21982	24267
700	1027	2395	4449	7186	10950	17052	23444	30937	34220

**Max. differential pressure**

Max. differential pressure with valve closed and a temperature up to 35°C is for all sizes 25 bar. At temperatures above 35°C the maximum differential pressure shall be multiplied with a factor "a" according to the graph below.

At 70° open valve is the maximum differential pressure at 35°C limited according to Technical specification on page 2. The same reduction of these differential pressure at temperatures above 35°C as for the valve closed is valid.

(See the graph below).

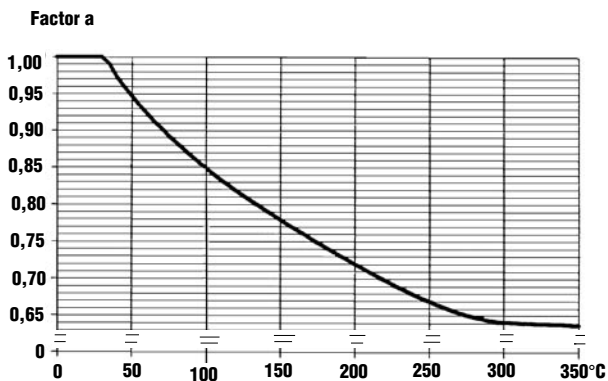

### Operating torque, Nm (Table 2)

DN	Differential pressure (bar)			
	10	16	20	25
80	50	60	67	75
100	70	85	100	110
125	95	115	136	150
150	140	170	200	230
200	300	350	400	470
250	500	600	720	850
300	750	980	1100	1250
350	1100	1400	1620	1900
400	1600	2000	2370	2700
500	2800	3500	4090	4700
600	4600	5800	6700	7700
700	7560	9600	10970	12600

### Operating torque

The above table specifies the torque necessary for closing the valve to the specified tightness. To achieve the specified tightness, the minimum design torque is corresponding to a differential pressure of 10 bar. At flow through the valve the disc is being affected by dynamic torque which tries to close the valve. At liquid flow and high velocities this may be decisive for selection of actuator size. In general, for this valve, it is valid that water velocities below 8 m/s in the pipe line at fully open valve do not give a dynamic torque higher than the closing torques according to the above table. This means that it is utmost rare that the dynamic torque is decisive for the actuator selection. In doubts, consult Flowserve concerning the torque required for actuator selection.

### Sizing of control valves

We have a valve sizing tool named Performance! This program can be ordered through your Flowserve representative. The program is based on calculating formula according to the standards IEC 60534 and ISA S75.01.

### Materials (Table 3)

Item	Qty	Part	Material	Remark
1a	1	Body	EN 1.4408/CF8M	
1b	1	Body	EN 1.0619	Carbon steel version
2	1	Disc	EN 1.4408/CF8M	
4a	1	Stem, upper	EN 1.4460	
4b	1	Stem, upper	EN 1.4462	NACE-version
5a	1	Stem, lower	EN 1.4460	
5b	1	Stem, lower	EN 1.4462	NACE-version
6	1	Clamp ring	DN >250 EN 1.4408/CF8M DN <=250 EN 1.4436/AISI316	
7	1	Retaining	EN 1.4436	
8	1	Gasket	Graphite	
9	1	Gasket	Graphite	
10	1	Seat ring	Inconel 718	
14	1	Seat ring	PTFE carbon reinforced	
15	1	Clamp ring	DN >250 EN 1.4408/CF8M DN <=250 EN 1.4436/AISI316	PTFE-version
18	1	O-ring	FPM	
20	1	Backing ring	PTFE	
21	1	Boxpacking set	Graphite	
22		Cup spring	17-7PH	For SafeGuard version
23	1	Gland cover	EN 1.4408/CF8M	
24	1	Boxpacking set	V-ring PTFE virgin/ PTFE 25 % C	
26	1	Stem bearing	PTFE lined	
27	1	Stem bearing	PTFE lined	
28	2	Pin screw	A4	
29	2	Nut	A4	
31		Screw	A4	
33a	3	Pin	DN<=500 EN 1.4436 DN>500 EN 1.4460	
33b	3	Pin	DN<=500 EN 1.4436 DN>500 EN 1.4462	NACE-version
36	2	Key	Stainless steel	
37	1	Washer	PTFE lined	
38	2	Retaining plate	DN<=200 EN 1.4436 DN>200 EN 1.4460	

- 1) Clamp ring item 15 must be included if the valve is to be converted from some other type of seat to a PTFE seat ring.
- 2) Quantity depending on dimension.
- \*) Recommended spare parts.

Other material combinations are available to order - consult Flowserve.

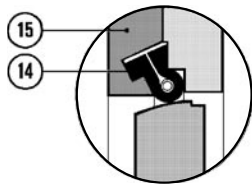

Seat type A (PTFE)

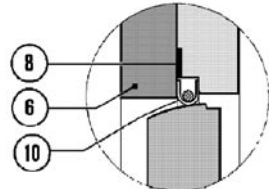

Seat type B (Inconel)

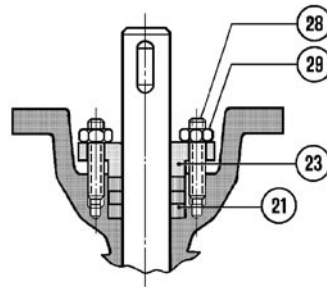

Stem seal type G and H

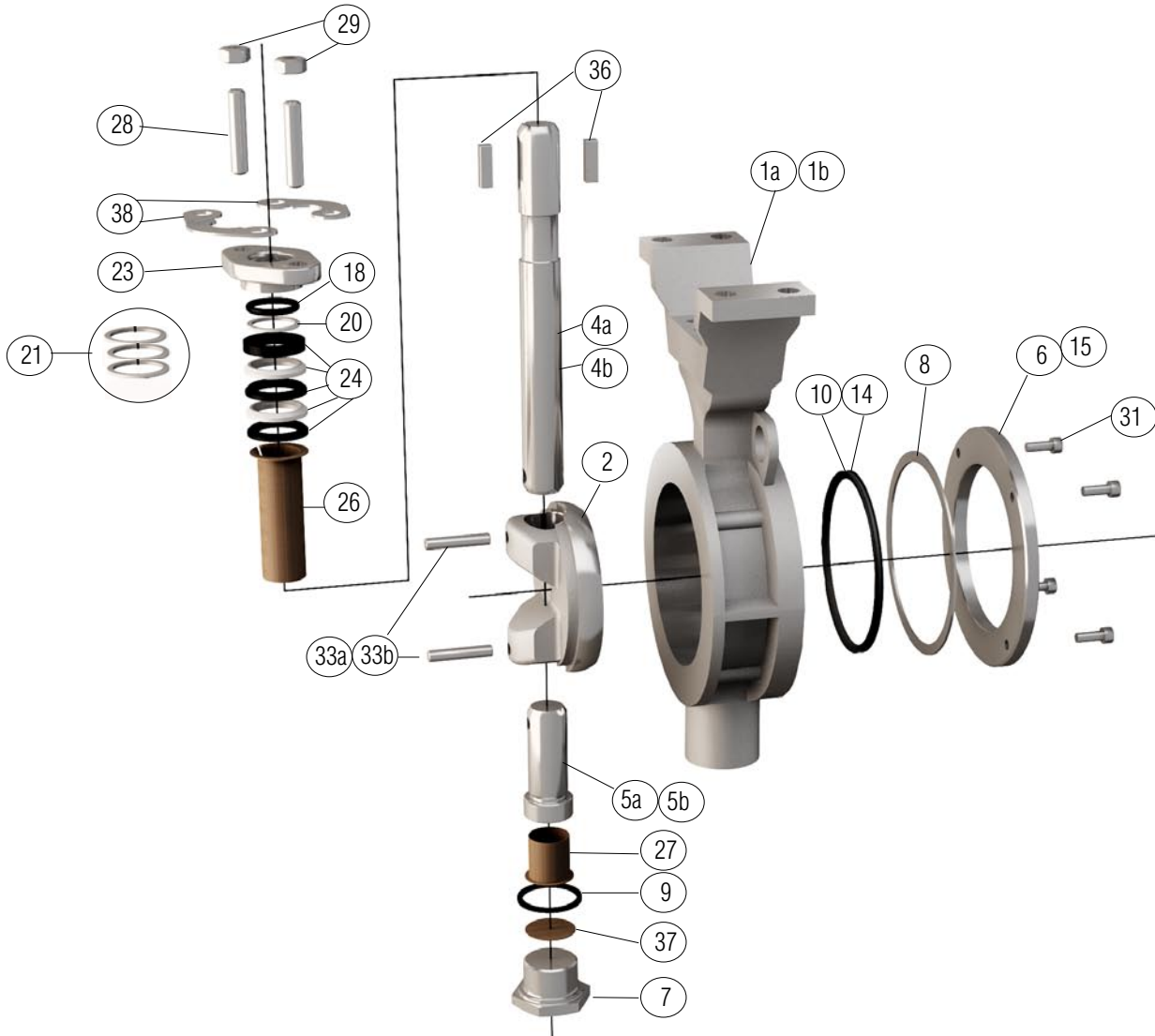

**Dimensions and mass**

Dimensions for stem and keyway, see Fk 95.10.

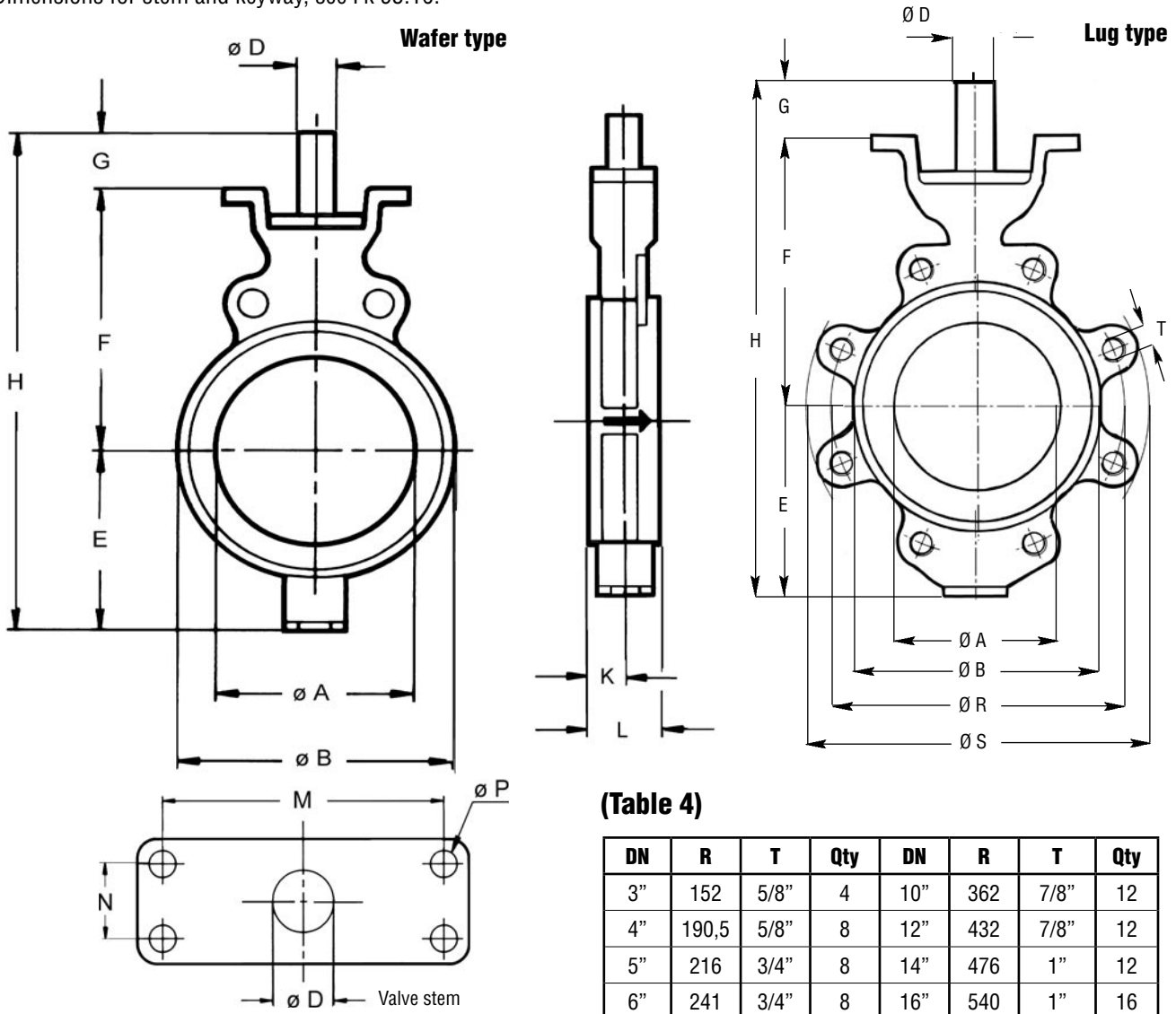

**(Table 4)**

DN	R	T	Qty	DN	R	T	Qty
3"	152	5/8"	4	10"	362	7/8"	12
4"	190,5	5/8"	8	12"	432	7/8"	12
5"	216	3/4"	8	14"	476	1"	12
6"	241	3/4"	8	16"	540	1"	16
8"	289,5	3/4"	8	20"	635	1 1/8"	20

**Actuator mounting**

**PN 10-25, ANSI Class 150 Wafer type and Lug type (Table 5)**

DN	A	B	D	E	F	G	H	K	L		M	N	P	S	Mass, kg	
									Wafer	Lug					Wafer	Lug
80	83	132	20	105	157	43	305	24,5	49	49	115	30	11	182	5	7
100	105	160	25	123	175	50	348	26	53	54	115	30	11	223	7	12
125	117	190	25	129	190	50	369	28	56	-	115	30	11	-	9	-
150	143	215	25	141	205	50	396	28	56	57	115	30	11	281	11	19
200	194	270	30	172	243	59	474	31	62	64	160	40	14	339	20	33
250	242	325	35	207	276	65	548	33	70	71	160	40	14	412	29	46
300	292	375	40	239	315	80	634	36	80	81	214	60	18	480	44	72
350	326	435	40	264	354	80	698	33	92	92	214	60	18	526	63	101
400	372	485	50	296	394	93	783	43	102	102	214	60	18	592	94	140
500	472	590	60	382	459	111	952	55	127	127	214	60	18	687	140	210
600	566	690	70	474	541	131	1146	63	154	154	277	115	33	830	281	400
700	670	802	80	555	584	149	1288	74,5	165	-	277	115	33	-	420	

All dimensions in mm

### Actuators

Valtek Torex TX is available with hand levers or with pneumatic or electric actuators and accessories. Use the following tables for selecting the hand levers and standard pneumatic actuators.

If other pneumatic or electric actuators are required, consult your Flowserve representative.

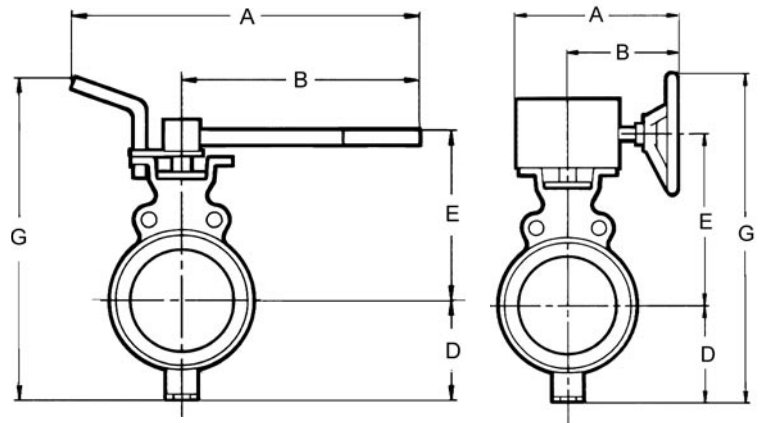

### Torex TX with hand levers (Table 7)

Valve size DN	Max dp bar	NAF No.	Dimensions, mm					Mass kg <sup>1)</sup>
			A	B	D	E	G	
<b>Hand lever as per Fk 70.51</b>								
80	25	791020-2	500	350	105	197	382	7
100	25	-3	500	350	123	215	418	9
125	20 <sup>3)</sup>	-3	500	350	129	230	439	11
150	-	-3	500	350	141	245	466	13
<b>Worm gear actuator as per Fk 70.76 <sup>2)</sup></b>								
80	25	791051-11020	249	174	105	191	396	9
100	25	791051-11025	249	174	123	209	432	11
125	25	791051-11025	249	174	129	224	453	13
150	25	791051-11025	249	174	141	239	480	15
200	25	791051-22030	328	243	172	286	608	29
250	25	791051-22035	328	243	207	319	676	38
300	25	791051-33040	416	291	239	365	804	61
350	25	791051-33040	416	291	264	404	868	80
400	16	791051-33050	416	291	296	459	955	111
400	25	791051-43050	507	337	296	449	995	126
500	19	791051-43060	507	337	382	514	1146	172
500	25	791051-53060	591	421	382	514	1096	178
600	19	791051-55070	591	421	474	621	1295	319
600	25	791051-65070	697	487	474	630	1404	348
700	25	791051-65080	697	487	555	658	1513	487

1) Wafer type PN 10-25, ANSI Class 150

2) Available with locking device. Contact Flowserve.

3) Metal seat only (PTFE choose gear)

All dimensions in mm

**Valtek Torex TX valves with pneumatic actuators (Table 8)**

The below stated dP apply for clean media type water 20 °C.  
For other media contact Flowserve, see also page 4

Valve size DN	Max dp bar at supply of			NAF No.	Dimensions, mm									Mass kg <sup>2)</sup>
	4 bar	5 bar	6 bar		A	B	C	D	E	F	G <sup>1)</sup>	H	R	
<b>Double-acting as per Fk 74.59</b>														
80	25	25	25	791390-0220	370	185	80	105	208	259	459	31	70	9
100	12	18	25	-0225	370	185	80	123	226	277	495	31	70	11
100	25	25	25	791290-1225	490	245	100	123	231	287	505	40	70	13
125	-	11	18	791390-0225	370	185	80	129	241	292	516	31	70	13
125	25	25	25	791290-1225	490	245	100	129	246	302	526	40	70	15
150	13	20	25	791290-1225	490	245	100	141	261	317	553	40	70	17
150	25	25	25	-2125	700	350	145	141	280	353	589	63	70	28
200	12	18	25	-2130	700	350	145	172	318	391	658	63	80	37
200	25	25	25	-2230	700	350	145	172	318	391	658	63	80	37
250	17	22	25	-2235	700	350	145	207	351	424	726	63	80	46
250	25	25	25	-3135	820	410	200	207	382	474	776	75	80	58
300	-	10	16	-2240	700	350	145	239	390	463	797	63	120	61
300	20	25	25	-3140	820	410	200	239	415	507	841	75	120	73
350	-	14	20	-3140	820	410	200	264	454	546	905	75	120	92
350	25	25	25	-3240	820	410	200	264	454	546	905	75	120	92
400	-	-	10	-3150	820	410	200	296	494	586	977	75	120	123
400	16	23	25	-3250	820	410	200	296	494	586	977	75	120	123
400	25	25	25	791390-4250	1110	555	260	296	522	625	1016	100	120	139
500	-	-	12	-4160	1110	555	260	382	587	690	1167	100	120	185
500	20	25	25	-4260	1110	555	260	382	587	690	1167	100	120	185
600	-	12	16	-4270	1110	555	260	474	705	808	1377	100	150	326
600	25	25	25	-5170	1600	800	395	474	723	871	1440	150	150	501
700	11	17	24	-5180	1600	800	395	555	766	914	1564	150	-	
700	25	25	25	-5280	1600	800	395	555	766	914	1564	150	-	
<b>Single-acting, spring to close as per Fk 74.59</b>														
80	25	25	25	791292-1220	635	390	100	105	213	269	469	40	70	14
100	14	14	14	791292-1225	635	390	100	123	231	287	505	40	70	16
100	25	25	25	-2225	890	540	145	123	250	323	541	63	70	30
125	25	25	25	-2225	890	540	145	129	265	338	562	63	70	32
150	25	25	25	-2225	890	540	145	141	280	353	589	63	70	34
200	15	15	15	-2230	890	540	145	172	318	391	658	63	80	43
200	25	25	25	-3230	1050	640	200	172	343	435	702	75	80	63
250	25	25	25	-3235	1050	640	200	207	382	474	776	75	80	72
300	17	17	17	-3240	1050	640	200	239	415	507	841	75	120	87
300	25	25	25	791392-4240	1520	965	260	239	443	546	880	100	120	144
350	25	25	25	791392-4240	1520	965	260	264	482	585	944	100	120	163
400	18	18	18	791392-4250	1520	965	260	296	522	625	1016	100	120	194
400	25	25	25	-5250	2210	1370	395	296	576	724	1115	150	120	559
500	25	25	25	-5260	2210	1370	395	382	641	789	1266	150	120	675
600	25	25	25	-5270	2210	1370	395	474	723	871	1440	150	150	766
700	12	12	12	-5280	2210	1370	395	555	766	914	1564	150	-	

1) Including valve positioner  
2) Wafer type PN 10-25, ANSI Class 150



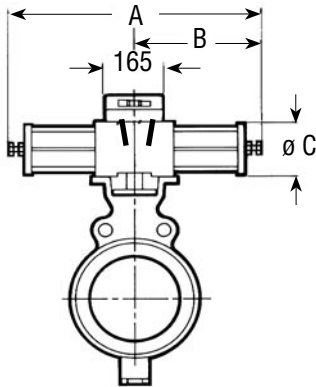

NAF 791290/791390

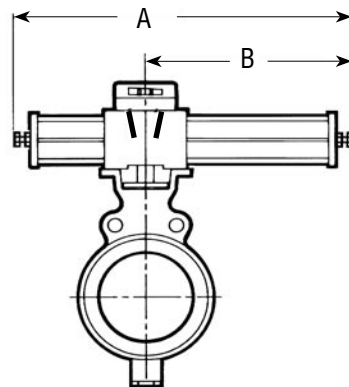

NAF 791292/791392

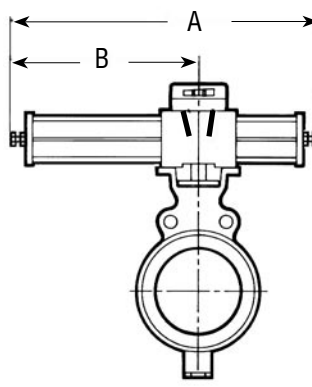

NAF 791294/791394

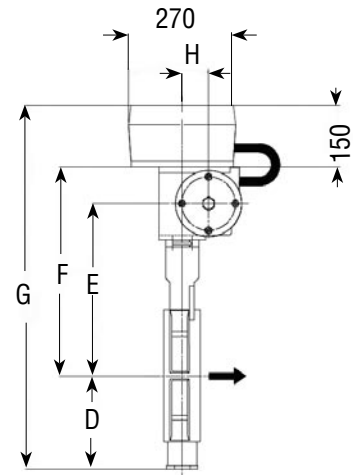

For high-level actuator installation, (design H) a spacer with height R is also required

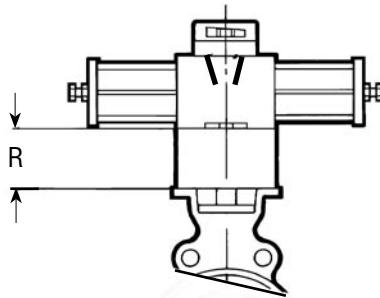

The below stated dP apply for clean media type water 20 °C. For other media contact Flowserve, see also page 4.

(Table 9)

Valve size DN	Max dp bar at supply of			NAF No.	Dimensions, mm									Mass kg <sup>2)</sup>
	4 bar	5 bar	6 bar		A	B	C	D	E	F	G <sup>1)</sup>	H	R	
<b>Single-acting, spring to open according to Fk 74.59</b>														
80	-	-	18	791394-0220	455	270	80	105	208	259	459	31	70	10
80	-	20	25	791294-1220	635	390	100	105	213	269	469	40	70	14
80	25	25	25	-2220	890	540	145	105	232	305	505	63	70	28
100	-	-	20	-1225	635	390	100	123	231	287	505	40	70	16
100	25	25	25	-2225	890	540	145	123	250	323	541	63	70	30
125	-	-	14	-1225	635	390	100	129	246	302	526	40	70	18
125	18	25	25	-2225	890	540	145	129	265	338	562	63	70	32
150	-	25	25	-2225	890	540	145	141	280	353	589	63	70	34
200	-	-	20	-2230	890	540	145	172	318	391	658	63	80	43
200	18	25	25	-3230	1050	640	200	172	343	435	702	75	80	63
250	-	25	25	-3235	1050	640	200	207	382	474	776	75	80	72
250	22	25	25	791394-4235	1520	965	260	207	410	513	815	100	80	129
300	-	14	20	791294-3240	1050	640	200	239	415	507	841	75	120	87
300	10	25	25	791394-4240	1520	965	260	239	443	546	880	100	120	144
350	-	-	10	791294-3240	1050	640	200	264	454	546	905	75	120	106
350	-	25	25	791394-4240	1520	965	260	264	482	585	944	100	120	163
400	-	12	25	791394-4250	1520	965	260	296	522	625	1016	100	120	194
400	25	25	25	-5250	2210	1370	395	296	576	724	1115	150	120	559
500	-	-	12	-4260	1520	965	260	382	587	690	1167	100	120	240
500	12	25	25	-5260	2210	1370	395	382	641	789	1266	150	120	675
600	-	22	25	-5270	2210	1370	395	474	723	871	1440	150	150	766
700	-	10	14	-5280	2210	1370	395	555	766	914	1564	150	-	-

1) Including valve positioner  
2) Wafer type PN 10-25, ANSI Class 150

**Accessories**

Flowserve's pneumatic actuator Turnex, see [www.flowserve.com](http://www.flowserve.com).

**Valve positioner**

Digital valve positioner, see [www.flowserve.com](http://www.flowserve.com).

**Terminal box**

The actuator can be equipped with a junction box (part No. 34920930) of cast aluminium containing terminal blocks for connecting the solenoid valve and position sensors.

**Fugitive emissions Approval, EN ISO15848-1**

Flowserve has certified some of our valves with a new stem sealing, according to EN ISO 15848-1 (this new standard will replace the old TA-luft standard). The packing box solution is with a V-ring set. The new packing set is live loaded with spring cups and equipped with an o-ring above the stem packing. Following valves have been certified in the first test.

Classification according to test results is **ISO-FE BH - CC1 - SSA0 - t200°C PN25**

**Classification classes:**

- BH Tightness class B, test fluid Helium
- CC1 20000 mechanical cycles, 2 thermal cycles.
- SSA0 Without shaft seal adjustments during test
- T200°C Temperature Class
- PN25 Endurance Class.

**Certified Products**

DN 80-350/Size 3"-14".

For other sizes and pressure classes contact Flowserve.

**Other material**

- CG8M code 23E...
- CF3M code 23G...
- CG3M code 23F...
- Duplex EN 1.4470 code 23D...
- Hastelloy C code 23H...
- 254 SMO code 23S...

Contact Flowserve for further information

**Other versions**

**- Degreased for oxygen**

Before assembly, all valve parts are degreased in trichlorethylene vapour in accordance with quality instructions Qi-207. The valve is assembled and packed so that no oil or grease will enter the valve.

*Product code: D*

**- Internal O-rings**

For protecting the stem bearings from the medium. For medium containing small, hard solid particles (such as those in flue gases, powders, granulates), and media that can cristalyze in narrow gaps. These medium can penetrate into the stem seal and give rise to increased actuating torque or increased wear.

O-ring seals are fitted between the body and the body side of the stems.

- PTFE seated valves FPM O-ring max 170°C
- Inconel seated valves PFM O-ring max 250°C
- Other combinations are possible

**- Explosive atmosphere acc. to Directive 94/9/EC ATEX**

Valtek Torex TX is certified according to ATEX 94/9/EC in  II 2 G/D c

*Product code: XA*

**Product code for Valtek Torex TX**

Example:

**23 8 3 B B - 0150 - B A A G B A D**  
**Code 1 2 3 4 5 6 7 8 9 10 11 12 13**

- |   |                                  |             |            |                                  |  |   |             |              |           |             |                |                |                 |                |                 |                |                 |                |                 |                |                 |                 |                 |                 |                 |                 |                 |                 |                 |                 |                 |                 |                 |                 |  |
|---|----------------------------------|-------------|------------|----------------------------------|--|---|-------------|--------------|-----------|-------------|----------------|----------------|-----------------|----------------|-----------------|----------------|-----------------|----------------|-----------------|----------------|-----------------|-----------------|-----------------|-----------------|-----------------|-----------------|-----------------|-----------------|-----------------|-----------------|-----------------|-----------------|-----------------|-----------------|--|
| <p><b>1. Valve type</b><br/> <b>23</b> Torex TX</p> <p><b>2. Material <sup>1)</sup></b><br/> <b>6</b> Carbon steel                      WCB / 1.0619<br/> <b>8</b> Stainless steel                      CF8M / 1.4408</p> <p><b>3. Pressure rating</b><br/> <b>2</b> PN 10                                      (DN 200-700) <sup>2)</sup><br/> <b>3</b> PN 16                                      (DN 100-700) <sup>3)</sup><br/> <b>4</b> ANSI Class 150                      (Size 3"-28")<br/> <b>5</b> PN 25                                      (DN 80-700)</p> <p><b>4. Stem bearing</b></p> <table border="0" style="width: 100%;"> <tr> <td style="text-align: center;"><b>Body</b></td> <td style="text-align: center;"><b>Stem</b></td> </tr> <tr> <td><b>A</b> -</td> <td>Hard chrome plated <sup>4)</sup></td> </tr> <tr> <td><b>B</b> PTFE lined bearing<br/>(max 250°C)</td> <td>-</td> </tr> </table> <p><b>5. Installation method</b><br/> <b>B</b> Wafer type<br/> <b>L</b> Lug type body ANSI Class 150<br/>(for PN classes cont. Flowserve)</p> <p><b>6. Size</b></p> <table border="0" style="width: 100%;"> <tr> <td style="text-align: center;">DIN-version</td> <td style="text-align: center;">ANSI-version</td> </tr> <tr> <td style="text-align: center;"><b>DN</b></td> <td style="text-align: center;"><b>Size</b></td> </tr> <tr> <td><b>0080</b> 80</td> <td><b>0003</b> 3"</td> </tr> <tr> <td><b>0100</b> 100</td> <td><b>0004</b> 4"</td> </tr> <tr> <td><b>0125</b> 125</td> <td><b>0005</b> 5"</td> </tr> <tr> <td><b>0150</b> 150</td> <td><b>0006</b> 6"</td> </tr> <tr> <td><b>0200</b> 200</td> <td><b>0008</b> 8"</td> </tr> <tr> <td><b>0250</b> 250</td> <td><b>0010</b> 10"</td> </tr> <tr> <td><b>0300</b> 300</td> <td><b>0012</b> 12"</td> </tr> <tr> <td><b>0350</b> 350</td> <td><b>0014</b> 14"</td> </tr> <tr> <td><b>0400</b> 400</td> <td><b>0016</b> 16"</td> </tr> <tr> <td><b>0500</b> 500</td> <td><b>0020</b> 20"</td> </tr> <tr> <td><b>0600</b> 600</td> <td><b>0024</b> 24"</td> </tr> <tr> <td><b>0700</b> 700</td> <td><b>0028</b> 28"</td> </tr> </table> <p><b>7. Seat ring</b><br/> <b>A</b> PTFE      max temp. 250°C<br/> <b>B</b> Inconel    max temp. 350°C</p> | <b>Body</b>                      | <b>Stem</b> | <b>A</b> - | Hard chrome plated <sup>4)</sup> | <b>B</b> PTFE lined bearing<br>(max 250°C) | - | DIN-version | ANSI-version | <b>DN</b> | <b>Size</b> | <b>0080</b> 80 | <b>0003</b> 3" | <b>0100</b> 100 | <b>0004</b> 4" | <b>0125</b> 125 | <b>0005</b> 5" | <b>0150</b> 150 | <b>0006</b> 6" | <b>0200</b> 200 | <b>0008</b> 8" | <b>0250</b> 250 | <b>0010</b> 10" | <b>0300</b> 300 | <b>0012</b> 12" | <b>0350</b> 350 | <b>0014</b> 14" | <b>0400</b> 400 | <b>0016</b> 16" | <b>0500</b> 500 | <b>0020</b> 20" | <b>0600</b> 600 | <b>0024</b> 24" | <b>0700</b> 700 | <b>0028</b> 28" | <p><b>8. Disc</b><br/> <b>A</b> CF8M / 1.4408</p> <p><b>9. Disc surface</b><br/> <b>A</b> None</p> <p><b>10. Seat ring seal/gasket bottom cover</b><br/> <b>G</b> Graphite</p> <p><b>11. Stem seal</b><br/> <b>A</b> Zebra-CL™                      max temp 250°C<br/> <b>B</b> Safeguard                      max temp 250°C<br/> <b>G</b> Graphite (box)                      max temp 350°C <sup>5)</sup><br/> <b>H</b> Graphite extended stem      max temp 350°C</p> <p><b>12. Stem material</b><br/> <b>A</b> EN 1.4460<br/> <b>B</b> UNS 17400/17-4PH NACE</p> <p><b>13. Other versions</b><br/> <b>D</b> Degreased version for oxygen<br/> <b>XA</b> ATEX certified</p> |
| <b>Body</b>   | <b>Stem</b>                      |             |            |                                  |  |   |             |              |           |             |                |                |                 |                |                 |                |                 |                |                 |                |                 |                 |                 |                 |                 |                 |                 |                 |                 |                 |                 |                 |                 |                 |  |
| <b>A</b> -  | Hard chrome plated <sup>4)</sup> |             |            |                                  |  |   |             |              |           |             |                |                |                 |                |                 |                |                 |                |                 |                |                 |                 |                 |                 |                 |                 |                 |                 |                 |                 |                 |                 |                 |                 |  |
| <b>B</b> PTFE lined bearing<br>(max 250°C)  | -                                |             |            |                                  |  |   |             |              |           |             |                |                |                 |                |                 |                |                 |                |                 |                |                 |                 |                 |                 |                 |                 |                 |                 |                 |                 |                 |                 |                 |                 |  |
| DIN-version   | ANSI-version                     |             |            |                                  |  |   |             |              |           |             |                |                |                 |                |                 |                |                 |                |                 |                |                 |                 |                 |                 |                 |                 |                 |                 |                 |                 |                 |                 |                 |                 |  |
| <b>DN</b>   | <b>Size</b>                      |             |            |                                  |  |   |             |              |           |             |                |                |                 |                |                 |                |                 |                |                 |                |                 |                 |                 |                 |                 |                 |                 |                 |                 |                 |                 |                 |                 |                 |  |
| <b>0080</b> 80  | <b>0003</b> 3"                   |             |            |                                  |  |   |             |              |           |             |                |                |                 |                |                 |                |                 |                |                 |                |                 |                 |                 |                 |                 |                 |                 |                 |                 |                 |                 |                 |                 |                 |  |
| <b>0100</b> 100   | <b>0004</b> 4"                   |             |            |                                  |  |   |             |              |           |             |                |                |                 |                |                 |                |                 |                |                 |                |                 |                 |                 |                 |                 |                 |                 |                 |                 |                 |                 |                 |                 |                 |  |
| <b>0125</b> 125   | <b>0005</b> 5"                   |             |            |                                  |  |   |             |              |           |             |                |                |                 |                |                 |                |                 |                |                 |                |                 |                 |                 |                 |                 |                 |                 |                 |                 |                 |                 |                 |                 |                 |  |
| <b>0150</b> 150   | <b>0006</b> 6"                   |             |            |                                  |  |   |             |              |           |             |                |                |                 |                |                 |                |                 |                |                 |                |                 |                 |                 |                 |                 |                 |                 |                 |                 |                 |                 |                 |                 |                 |  |
| <b>0200</b> 200   | <b>0008</b> 8"                   |             |            |                                  |  |   |             |              |           |             |                |                |                 |                |                 |                |                 |                |                 |                |                 |                 |                 |                 |                 |                 |                 |                 |                 |                 |                 |                 |                 |                 |  |
| <b>0250</b> 250   | <b>0010</b> 10"                  |             |            |                                  |  |   |             |              |           |             |                |                |                 |                |                 |                |                 |                |                 |                |                 |                 |                 |                 |                 |                 |                 |                 |                 |                 |                 |                 |                 |                 |  |
| <b>0300</b> 300   | <b>0012</b> 12"                  |             |            |                                  |  |   |             |              |           |             |                |                |                 |                |                 |                |                 |                |                 |                |                 |                 |                 |                 |                 |                 |                 |                 |                 |                 |                 |                 |                 |                 |  |
| <b>0350</b> 350   | <b>0014</b> 14"                  |             |            |                                  |  |   |             |              |           |             |                |                |                 |                |                 |                |                 |                |                 |                |                 |                 |                 |                 |                 |                 |                 |                 |                 |                 |                 |                 |                 |                 |  |
| <b>0400</b> 400   | <b>0016</b> 16"                  |             |            |                                  |  |   |             |              |           |             |                |                |                 |                |                 |                |                 |                |                 |                |                 |                 |                 |                 |                 |                 |                 |                 |                 |                 |                 |                 |                 |                 |  |
| <b>0500</b> 500   | <b>0020</b> 20"                  |             |            |                                  |  |   |             |              |           |             |                |                |                 |                |                 |                |                 |                |                 |                |                 |                 |                 |                 |                 |                 |                 |                 |                 |                 |                 |                 |                 |                 |  |
| <b>0600</b> 600   | <b>0024</b> 24"                  |             |            |                                  |  |   |             |              |           |             |                |                |                 |                |                 |                |                 |                |                 |                |                 |                 |                 |                 |                 |                 |                 |                 |                 |                 |                 |                 |                 |                 |  |
| <b>0700</b> 700   | <b>0028</b> 28"                  |             |            |                                  |  |   |             |              |           |             |                |                |                 |                |                 |                |                 |                |                 |                |                 |                 |                 |                 |                 |                 |                 |                 |                 |                 |                 |                 |                 |                 |  |

1) Other material see page 10  
2) DN 80 has the same flange dimensions in PN 10, 16 and 25, choose PN 25  
DN 100-150 has the same flange dimensions in PN 10 and 16, choose PN 16  
3) DN 80 choose PN 25  
4) Only in stainless steel version  
5) For temperatures above 250°C it's due to type of actuator version H or other type of stem extension recommended.

**Flowserve Corporation**

Flow Control  
1350 N. Mt. Springs Parkway  
Springville, UT 84663  
USA  
Phone: +1-801 489 8611  
Fax: +1-801 489 3719

**Flowserve (Austria) GmbH**

Control Valves - Villach Operations  
Kasernengasse 6  
9500 Villach  
Austria  
Phone: +43 (0) 42 42 41181-0  
Fax: +43 (0) 42 42 4118150

**Flowserve Pte Ltd.**

12 Tuas Avenue 20  
Republic of Singapore 638824  
Singapore  
Phone: (65) 68 798 900  
Fax: (65) 68 624 940

**Flowserve Essen GmbH**

Manderscheidtstrasse 19  
45141 Essen  
Germany  
Phone: +49 (0) 201 89 19 5  
Fax: +49 (0) 201 89 19 662

**Flowserve Linköping**

Gelbgjutaregatan 2  
58187 Linköping  
Sweden  
Phone: +46 (0) 13 31 61 00  
Fax: +46 (0) 13 13 60 54

**Flowserve S.A.S.**

7, Avenue de la Libération  
B.P. 60  
Thiers 63300  
France  
Phone: +33 (0)4 73 80 42 66  
Fax: +33 (0)4 73 80 14 24

**To find the sales location nearest you visit  
[Flowserve.com/SalesLocator](http://Flowserve.com/SalesLocator)**

For more information about Flowserve Corporation, visit  
[www.flowserve.com](http://www.flowserve.com)

VLEETB4143-02 11.04

**All data subject to change without notice**  
**©08. 000 Flowserve Corporation. Flowserve is a trademark of the Flowserve Corporation**